

No. 461 Straight Pipe Vise

Capacity: 1/2" through 8"

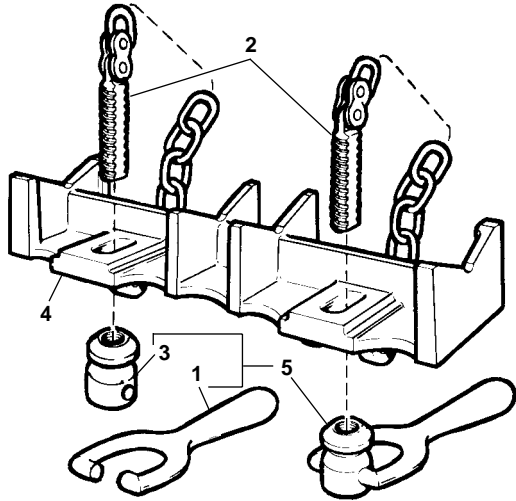

No. 463 Elbow Pipe Vise

Capacity: 2 1/2" through 8"

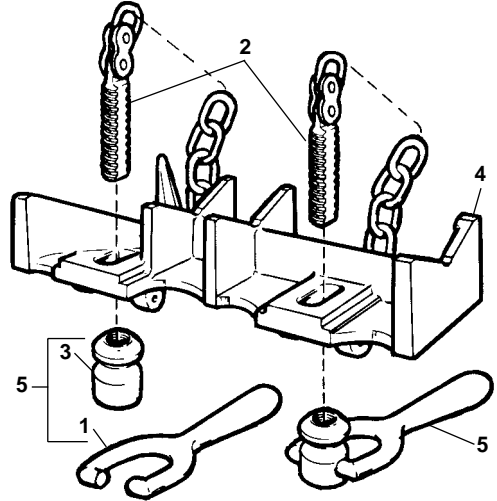

No. 462 Angle Pipe Vise

Capacity: 1/2" through 12"

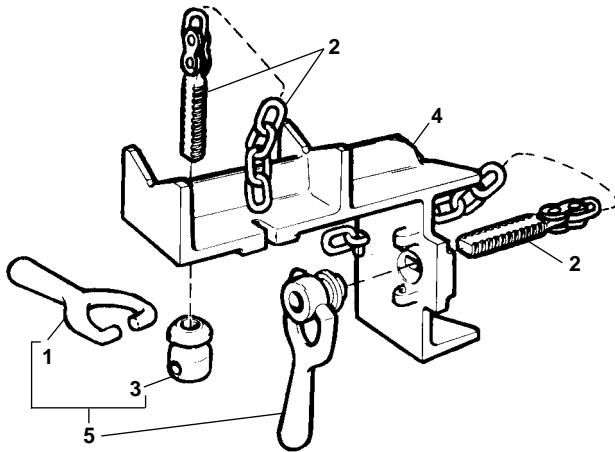

No. 464 Flange Pipe Vise

Capacity: 2 1/2" through 8"

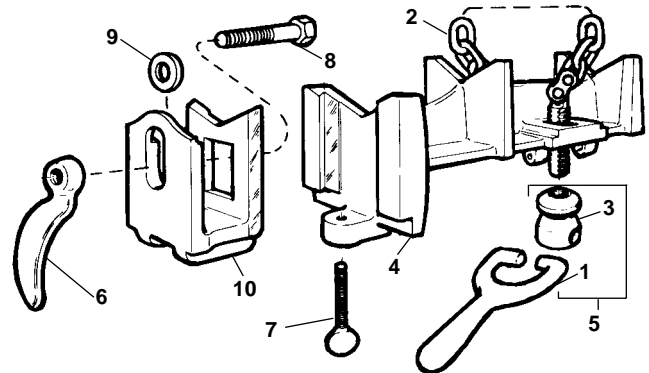

**NOTE: Order parts by Catalog Number only.
DO NOT order by Reference Number.**

Ref. No.	Description	461 Catalog No.	462 Catalog No.	463 Catalog No.	464 Catalog No.
1	Handle (2)*	32190	32190	32190	32190
2	Coil Chain and Screw Assembly (2)	41180	41180	41180	41180
3	Nut (2)*	40720	40720	40720	40720
4	Base w/Pivot Pins	41185	41190	41195	41225
5	Handle and Nut (2)*	40725	40725	40725	40725
6	Clamp Lever	—	—	—	41205
7	Adjusting Screw	—	—	—	41210
8	Bolt	—	—	—	41215
9	Flat Washer	—	—	—	41220
10	Slide Bracket	—	—	—	41200