

Motor/Frame Assembly

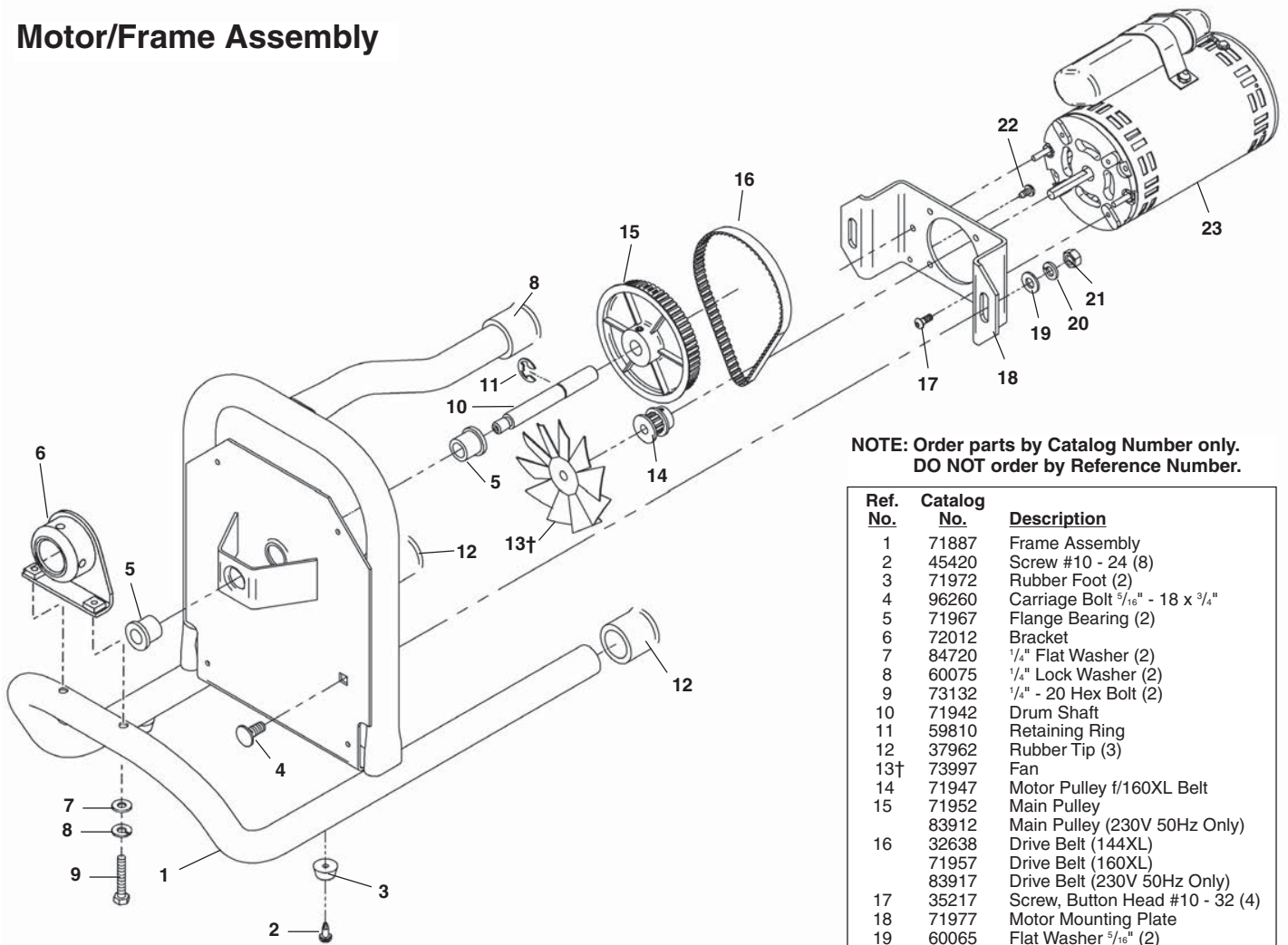

**NOTE: Order parts by Catalog Number only.
DO NOT order by Reference Number.**

Ref. No.	Catalog No.	Description
1	71887	Frame Assembly
2	45420	Screw #10 - 24 (8)
3	71972	Rubber Foot (2)
4	96260	Carriage Bolt $\frac{5}{16}$ " - 18 x $\frac{3}{4}$ "
5	71967	Flange Bearing (2)
6	72012	Bracket
7	84720	$\frac{1}{4}$ " Flat Washer (2)
8	60075	$\frac{1}{4}$ " Lock Washer (2)
9	73132	$\frac{1}{4}$ " - 20 Hex Bolt (2)
10	71942	Drum Shaft
11	59810	Retaining Ring
12	37962	Rubber Tip (3)
13†	73997	Fan
14	71947	Motor Pulley f/160XL Belt
15	71952	Main Pulley
	83912	Main Pulley (230V 50Hz Only)
16	32638	Drive Belt (144XL)
	71957	Drive Belt (160XL)
	83917	Drive Belt (230V 50Hz Only)
17	35217	Screw, Button Head #10 - 32 (4)
18	71977	Motor Mounting Plate
19	60065	Flat Washer $\frac{5}{16}$ " (2)
20	60080	Lock Washer $\frac{5}{16}$ " (2)
21	96730	Hex Nut $\frac{5}{16}$ " - 18 (2)
22	45420	Screw #10 - 24 (8)
23*	34898	Motor 115V 60Hz w/Thermal Breaker
	*	34903 Motor 230V 50Hz w/Thermal Breaker
		72022 Motor 100V 50/60Hz

1. Position Fan as Shown.

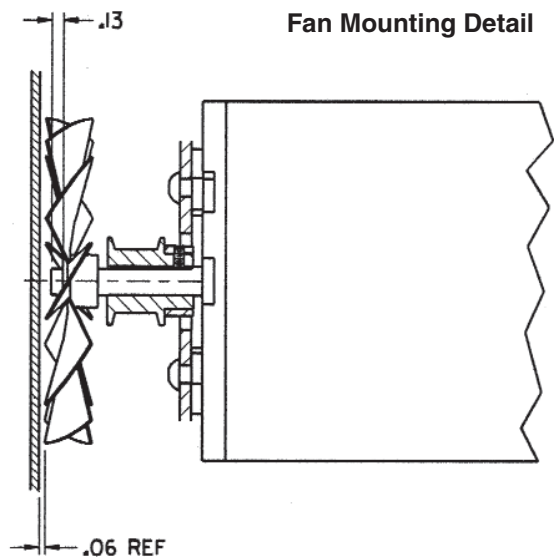

† Refer to Service Notes for Fan position.

* (Ref No. 19) If replacing motor model #1842424059 then you must also replace the motor shroud catalog #34908.

** If using new shroud with old motor must use plug #35233.

Motor/Frame Assembly

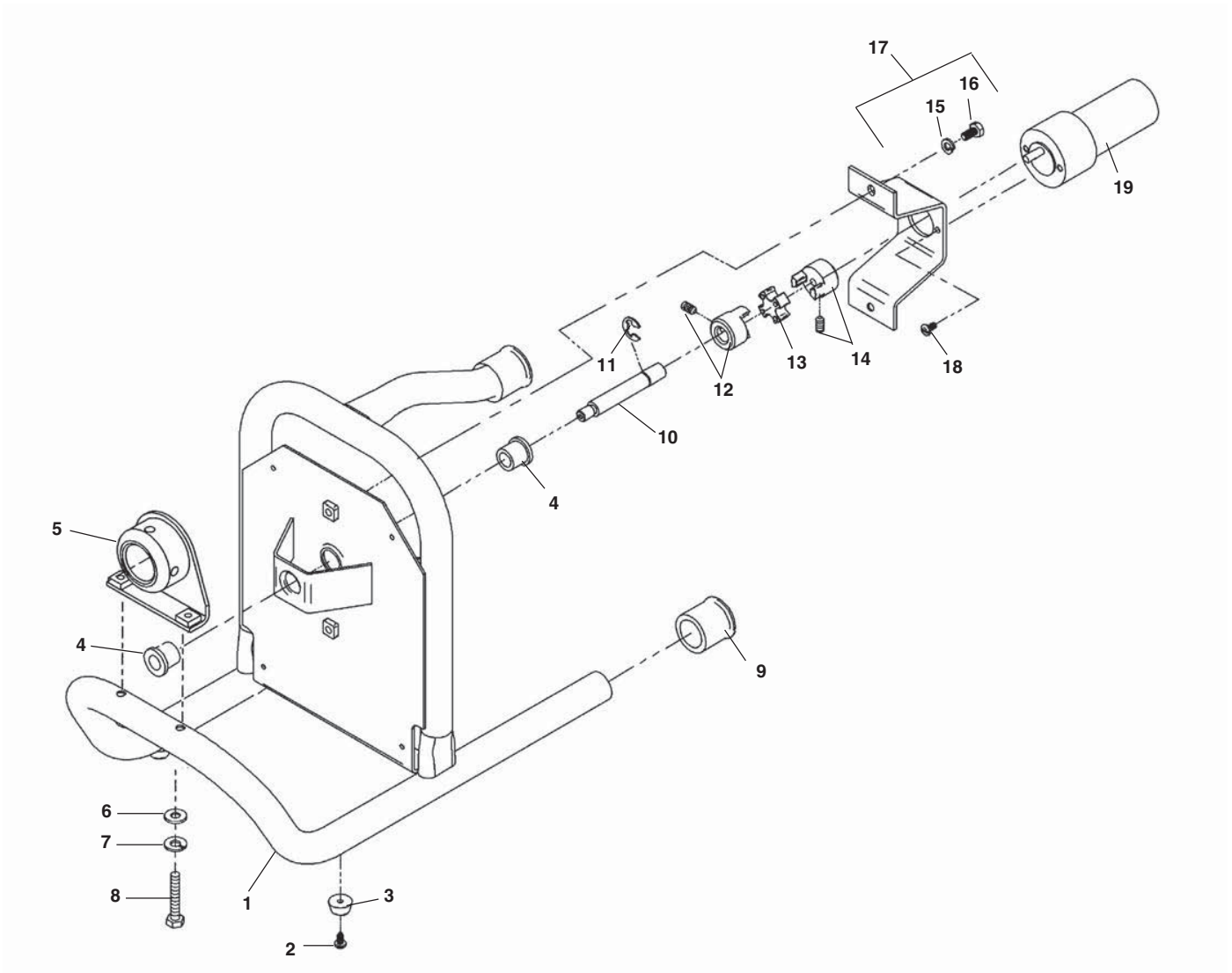

**NOTE: Order parts by Catalog Number only.
DO NOT order by Reference Number.**

Ref. No.	Catalog No.	Description
1	83357	K-40B Tubular Frame Assembly
2	45420	Screw #10 - 24 (8)
3	71972	Rubber Foot (2)
4	71967	Flange Bearing (2)
5	72012	Bracket
6	84720	1/4" Flat Washer (2)
7	60075	1/4" Lock Washer (2)
8	73132	Hex Bolt 1/4" - 20 (2)
9	37962	Rubber Tip (3)
10	83367	Drum Shaft
11	59810	Retaining Ring
12	83377	Coupling End 1/2"
13	83382	Coupling Spider
14	83372	Coupling End 1/4"
15	92615	Washer (2)
16	60265	Hex Screw 1/4" - 20 x 1/2"
17	83402	Motor Mounting Plate (Inc. Ref. No. 11, 12)
18	35217	Screw, Button Head #10 - 32 (2)
19	83397	Motor 14.4V

Drum Assembly

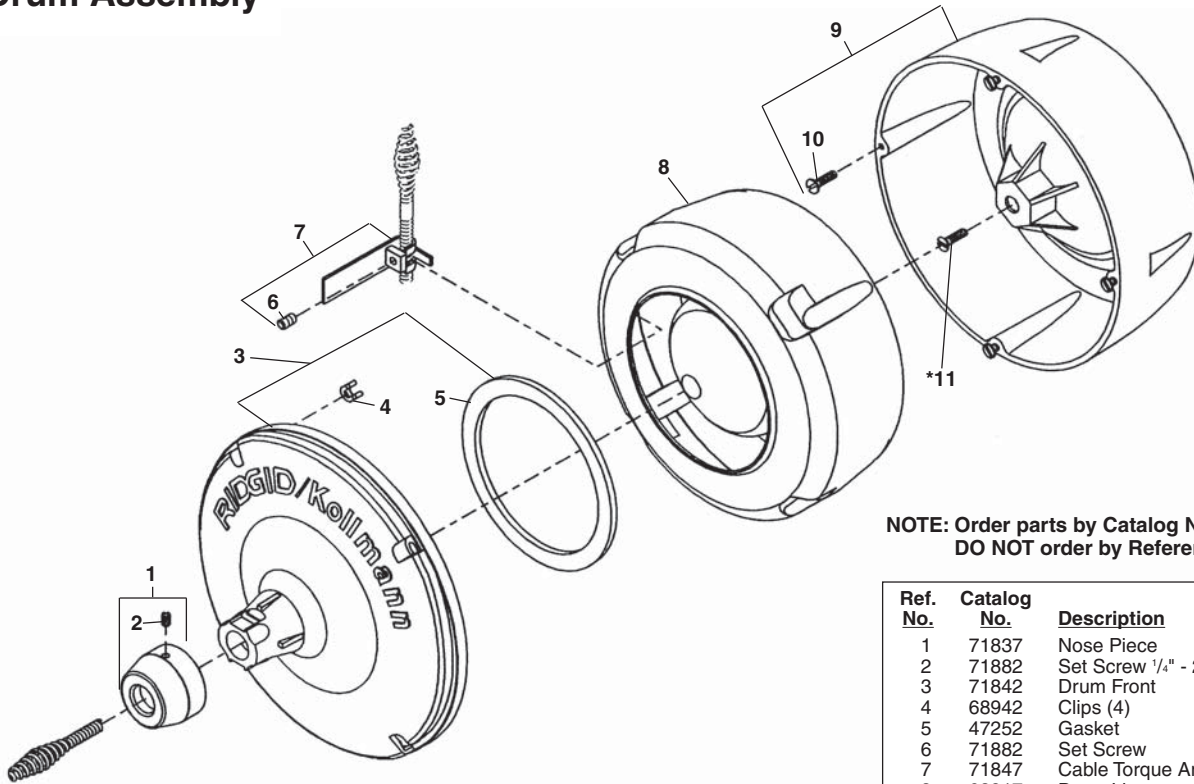

NOTE: Order parts by Catalog Number only. DO NOT order by Reference Number.

Ref. No.	Catalog No.	Description
1	71837	Nose Piece
2	71882	Set Screw 1/4" - 20 x 1/2"
3	71842	Drum Front
4	68942	Clips (4)
5	47252	Gasket
6	71882	Set Screw
7	71847	Cable Torque Arm
8	68917	Drum Liner
9	68932	Drum Back
10	69542	Screw #10 - 32 x 1" (4)
*11	76775	Screw L.H. Thread

Old Style AUTOFEED

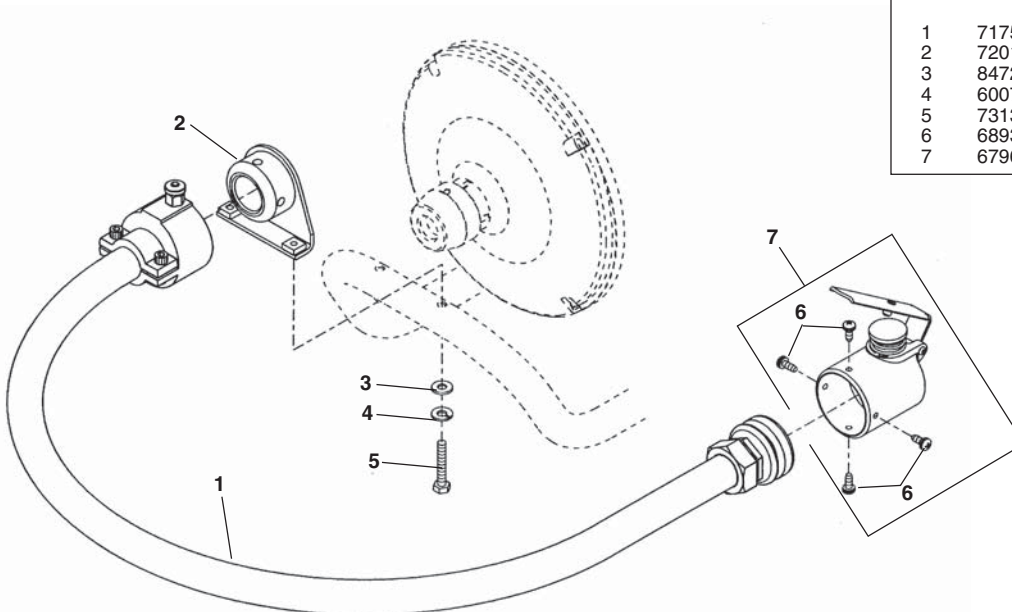

Ref. No.	Catalog No.	Description
-	71762	A-40G PF Guide Hose/AUTOFEED
1	71757	A-40G Guide Hose Assembly
2	72012	Bracket
3	84720	1/4" Flat Washer (2)
4	60075	1/4" Lock Washer (2)
5	73132	1/4" - 20 Hex Bolt (2)
6	68937	Pan Head Screw #10 -- 24 (4)
7	67962	A-39PF AUTOFEED

Guide Hose Assembly

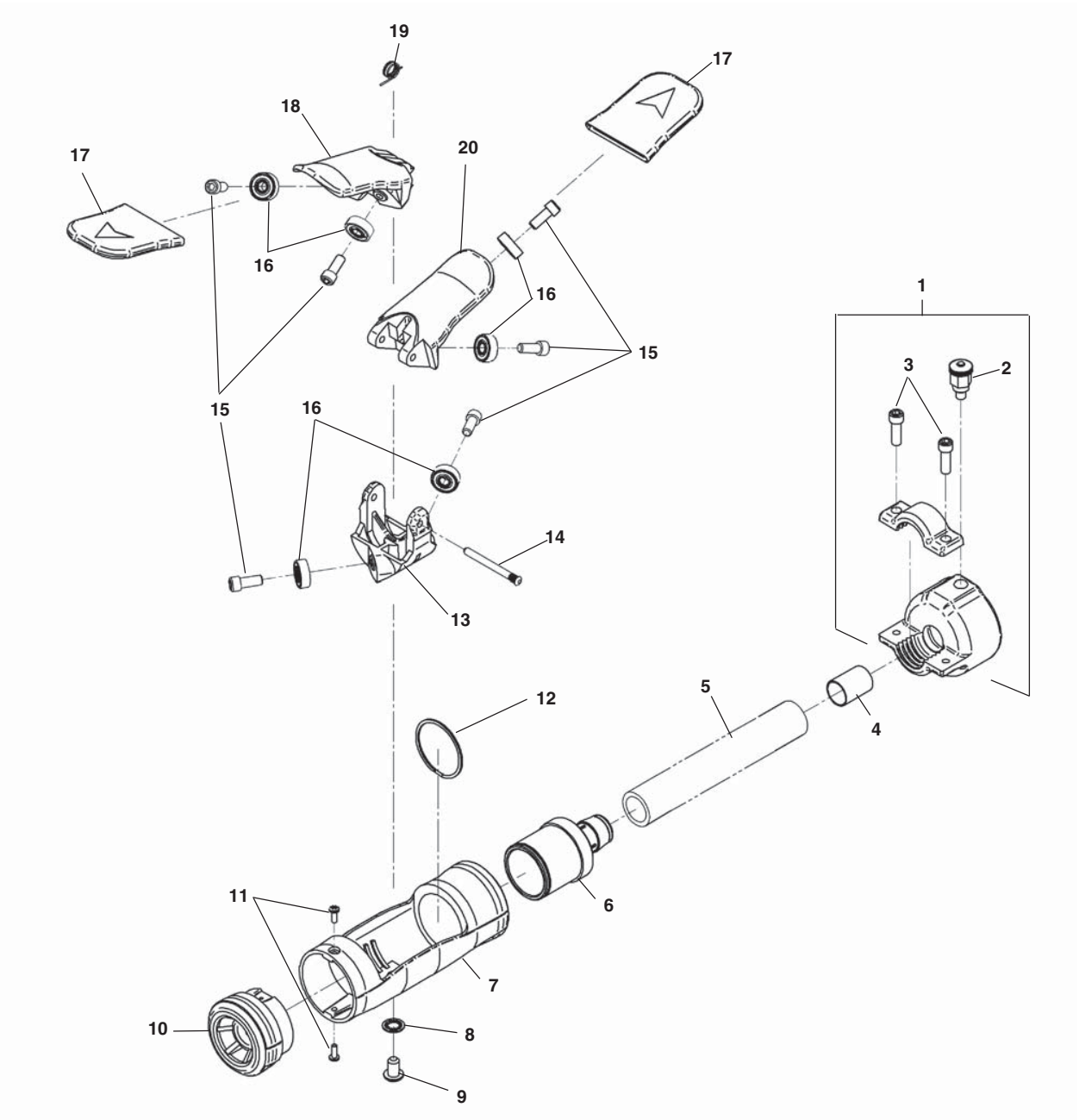

**NOTE: Order parts by Catalog Number only.
DO NOT order by Reference Number.**

Ref. No.	Catalog No.	Description	Ref. No.	Catalog No.	Description
—	26558	Guide Hose Assembly with AUTOFEED	11	24168	Screw #6 (2)
1	59815	Guide Hose Bracket	12	41512	Spiral Ring
2	59510	Plunger Pin	13	24213	AUTOFEED Carriage
3	40910	Hex Cap Screw (2)	14	24208	Pivot Pin
4	31258	Ferrule	15	39830	Socket HD Cap Screw 1/4" - 20 x 5/8" (6)
5	72467	Hose, 4'	16	67997	Roller Bearing (6)
6	31238	AUTOFEED Adapter	17	30138	Lever Grip (2)
7	31243	Handgrip	18	24223	Forward Lever
8	31248	Lock Washer, 5/16" Internal	19	24228	Torsion Spring
9	24178	Button Screw 5/16" - 18	20	24218	Reverse Lever
10	24163	Nose Piece			

Electric Components

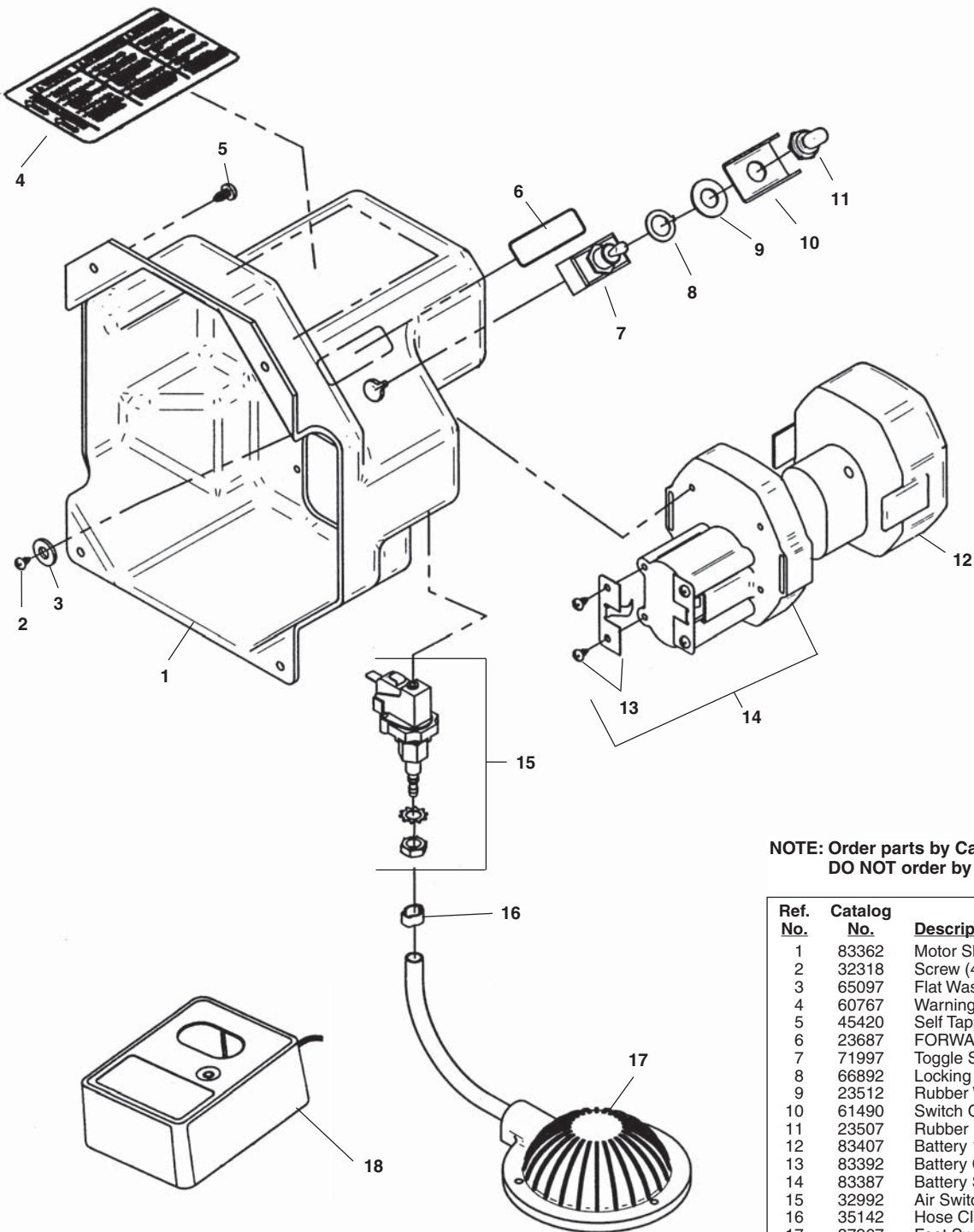

NOTE: Order parts by Catalog Number only. DO NOT order by Reference Number.

Ref. No.	Catalog No.	Description
1	83362	Motor Shroud
2	32318	Screw (4)
3	65097	Flat Washer #6
4	60767	Warning Label
5	45420	Self Tapping Screw #10 - 24 (8)
6	23687	FORWARD/REVERSE Label
7	71997	Toggle Switch
8	66892	Locking Ring
9	23512	Rubber Washer
10	61490	Switch Guard
11	23507	Rubber Boot
12	83407	Battery 14.4V
13	83392	Battery Clips w/Screws
14	83387	Battery Socket Assembly
15	32992	Air Switch
16	35142	Hose Clamp
17	37967	Foot Switch Assembly
18	83417	Charger 115V
	84112	Charger 230V

Electric Components

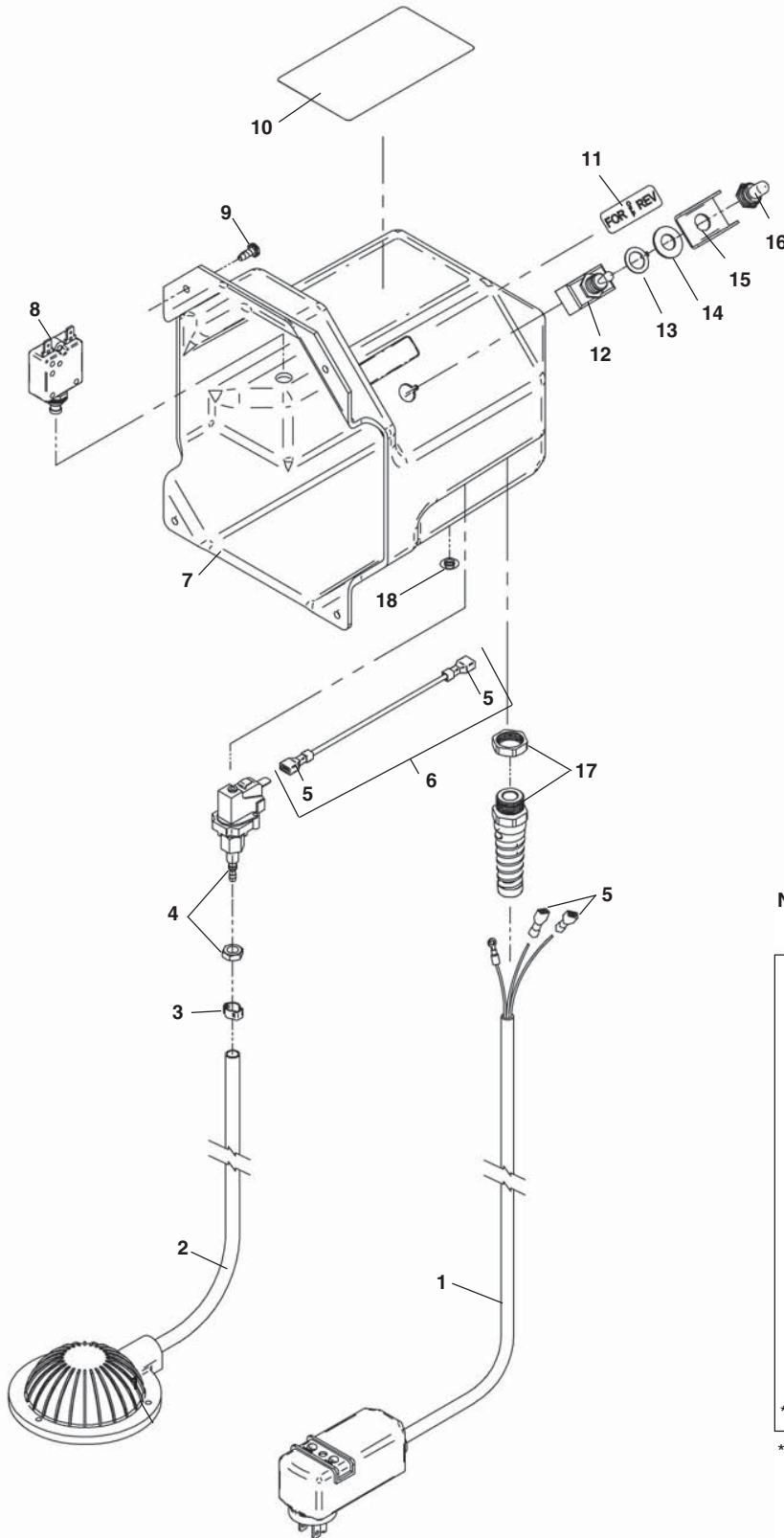

**NOTE: Order parts by Catalog Number only.
DO NOT order by Reference Number.**

Ref. No.	Catalog No.	Description
1	50507	Line Cord w/GFCI - 115V
	66882	Line Cord - 100V Japan
	15707	Line Cord - 230V Export
2	37967	Foot Switch Assembly
3	35142	Hose Clamp
4	32992	Air Switch
5	72007	Quick Disconnect (4)
6	73012	Lead Wire
*7	34908	Shroud
8	34958	Thermal Circuit Breaker
9	45420	Self Tapping Screw #10 - 24 (8)
10	60767	Warning Label
11	23687	FORWARD/REVERSE Label
12	71997	Toggle Switch
13	66892	Locking Ring
14	23512	Rubber Washer
15	61490	Switch Guard
16	23507	Rubber Boot
17	65817	Strain Relief
18	74447	Plug
**19	35233	Plug (NOT SHOWN)

** If using new shroud with old motor must use plug #35233.

Electrical Components

Europe
Australia
U.K.

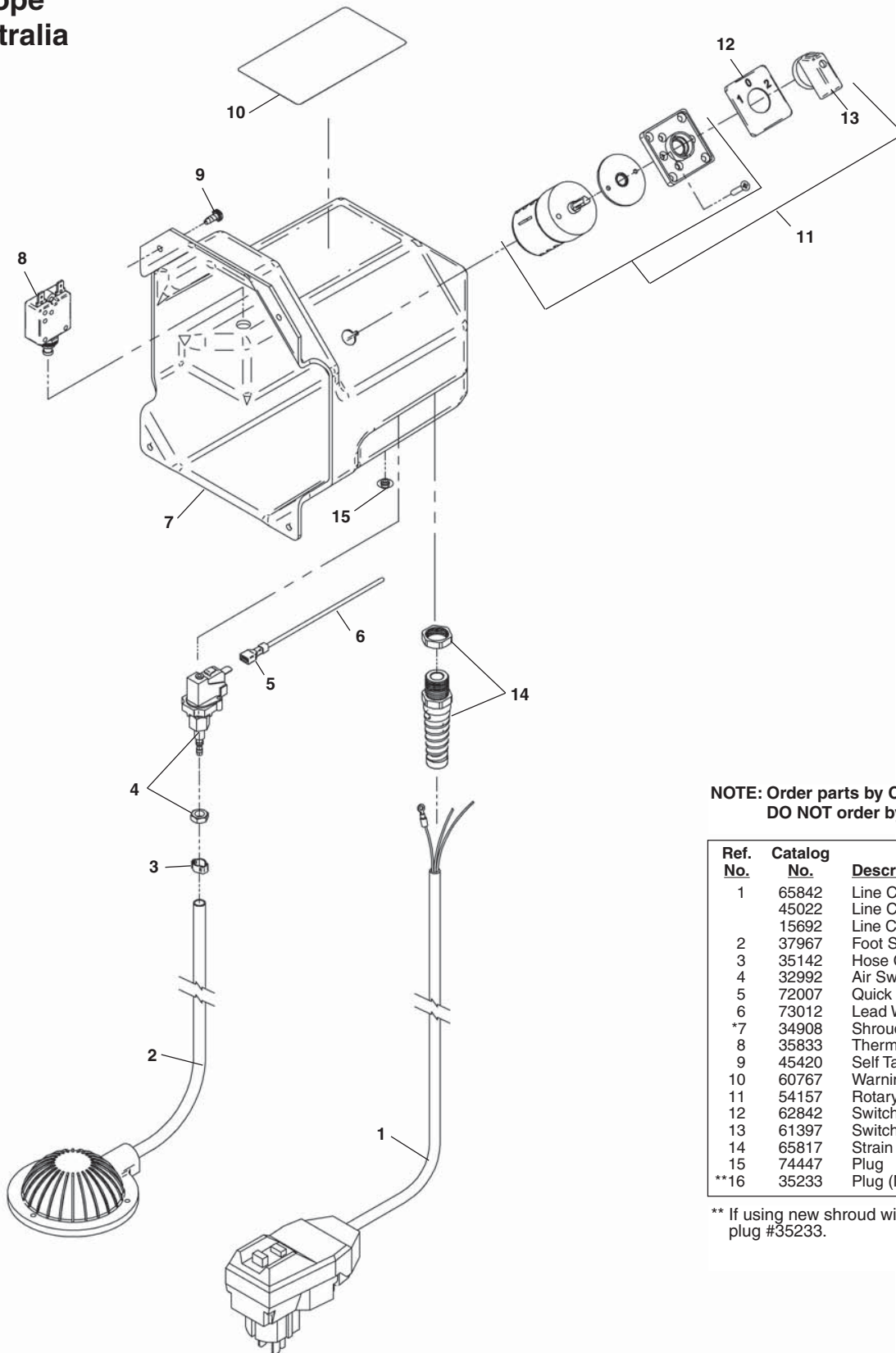

**NOTE: Order parts by Catalog Number only.
DO NOT order by Reference Number.**

Ref. No.	Catalog No.	Description
1	65842	Line Cord w/GFCI-220V Europe
	45022	Line Cord w/Plug 110V U.K.
	15692	Line Cord w/Plug 240V Australia
2	37967	Foot Switch Assembly
3	35142	Hose Clamp
4	32992	Air Switch
5	72007	Quick Disconnect
6	73012	Lead Wire
*7	34908	Shroud
8	35833	Thermal Circuit Breaker
9	45420	Self Tapping Screw #10 - 24 (8)
10	60767	Warning Label
11	54157	Rotary Switch
12	62842	Switch Plate
13	61397	Switch Knob
14	65817	Strain Relief
15	74447	Plug
**16	35233	Plug (NOT SHOWN)

** If using new shroud with old motor must use plug #35233.

K-40 Wiring

MOTOR WIRING DIAGRAM

115V/60Hz

230V/50Hz Export

100V/50-60Hz Japan

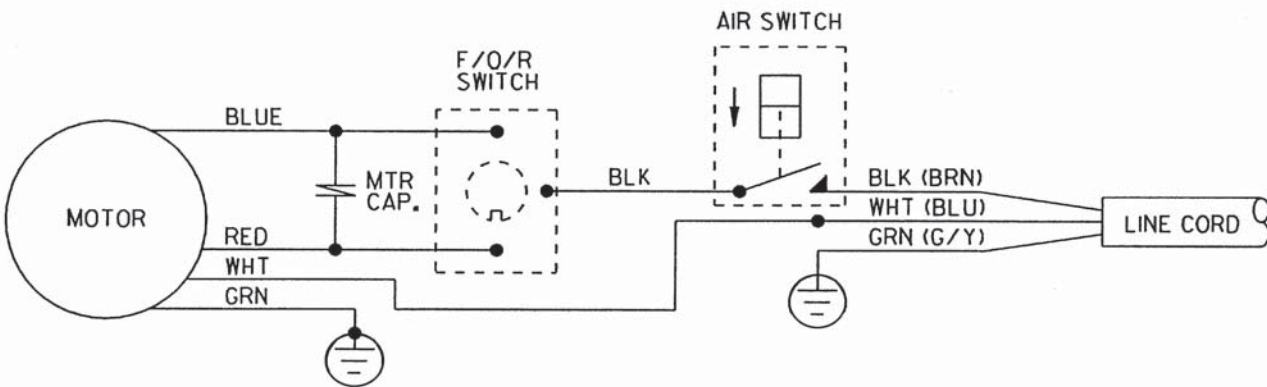

MOTOR WIRING DIAGRAM

230V/50Hz Europe

240V/50Hz Australia

110V/50Hz U.K.

